

# WRIGHT METAL PARTITION



INTERCHANGEABLE

WRIGHT METAL INC.  
JAMESTOWN, N.Y.

## SPECIAL FEATURES OF WRIGHT METAL PARTITIONS



Unit Principle of Flexibility Wright partitions are constructed in a series of units—of varying widths—Each unit is complete in itself—The units can be used in any of the several types of Wright Metal partitions—THEY ARE FLEXIBLE.

—

Unit Cornice Not Continuous All cornice sections are perfectly straight and delicate in line—graceful in design—yet rugged in construction—They are jig mitered on both ends—hence they are absolutely interchangeable for any angle, straight or corner run of partition.

—

Salvage Value, the True Test of Economy All Wright Metal partitions retain their original value in salvage—When not in use they are ever ready for instant reerection—Any location—There are no extras—THEY ARE COMPLETE.

—

Durability Wright Metal partitions are built to last a lifetime.

Appearance and Finish Wright Metal partitions are unsurpassed in finish and appearance—Skill in design, ingenious machinery in manufacture—personal pride of the individual craftsman—these factors are producing a most beautiful partition—Every coat of finish, from the mineral filler and primer through to the final enamel coat, is of the best materials obtainable—All coats are applied by sprayers and grainers of many years' experience—Each coat is baked in modern temperature-controlled electric ovens—THE FINISH IS PERMANENT.

—

Interchangeability of Units All Wright Metal panel units of one type of partition are interchangeable with all other types—They can be reversed.

—

Utility Usefulness of Wright Metal partitions has been proved by ample trial—They have no weakness—They are adaptable for all partition requirements—THEY are UNEXCELLED.

---

**"It Is Not What You Pay — But What You Get For What You Pay — That Counts"**

---

# WRIGHT METAL PANEL UNIT

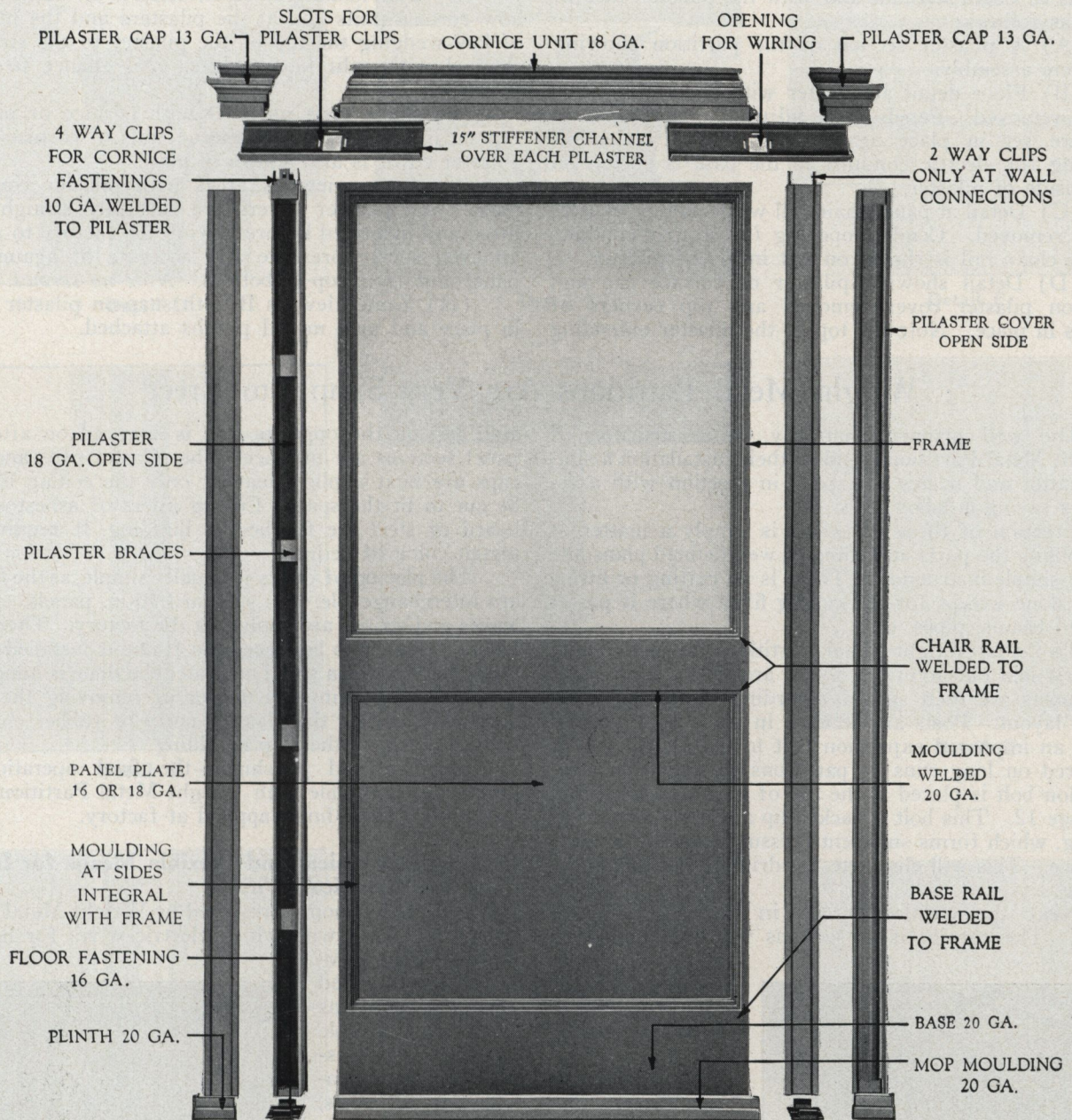

The above illustration shows all parts forming one complete panel unit of the Wright Metal Partition. All parts are interchangeable, making it possible to assemble Wright Metal Partitions in any arrangement desired to fit the space and floor plans. They may be rearranged, when necessary, easily and without loss.

## GENERAL CONSTRUCTION FEATURES

### Wright Metal Partitions

On the following page a series of composite photographs illustrate the partition as completely erected as well as in detail without and with the pilaster face in place as follows:

(A) A pilaster section of the partition showing complete assembly.

(B) Floor detail at pilaster with snap-on pilaster cover removed. Panels with adjustable mop moulding are set in place against the pilaster. Conduit opening for electric conduits in the base is shown on left inside of pilaster.

(C) Detail at panel chair rail with snap-on pilaster cover removed. Conduit opening for electric conduits in the chair rail is shown on left inside of pilaster.

(D) Detail showing pilaster or cornice cap and snap-on pilaster cover removed and top corners of panels in place. Note the top of the pilaster extending

up through stiffener channel for securing with key wedges.

(E) Plan looking down on detail at D. This shows how cornice units end at the pilasters and the method of key wedging the top of the pilaster to the stiffener channel with split key wedges. No chance to work loose.

(F) Same view as at D with cornice or pilaster cap set in place covering mitered ends of cornice units. Pilaster cover is also shown in place.

(G) Same view as at C with pilaster cover in place. All pilaster covers are carefully straightened, fitted and inspected before leaving the factory to assure an even spring pressure and accurate fit against the panel unit from top to bottom. *Note no screws.*

(H) Same view as B with snap-on pilaster cover in place and mop mould plinths attached.

### Wright Metal Partitions Are Very Simple to Erect

The well planned simplicity of construction of Wright Metal Partitions renders their installation a simple matter and makes for speed in erection with a resulting saving in labor costs.

Erection of these partitions is simply a matter of assembling the parts according to well defined plans and a few simple instructions. There is no cutting or fitting to be done except for the ceiling filler where it passes around beams, pipes, etc.

To install Wright Metal Partitions the center lines are first laid out according to the architect's floor plans. The posts are then spaced according to the approved panel layout. Posts are secured in place by means of using an improved expansion bolt to the floor. Where required on long runs of partitions an extension compression bolt is placed in the top of each post as shown on page 12. This bolt is backed up against plates at the ceiling, which forms sufficient pressure to hold the posts in place. This will eliminate the drilling of holes in the ceiling.

Next the cornice is set in place on top of posts. The cornice is in sections which extend from center of post to center of post so that it is possible to remove any portion from floor to cornice between posts. After cornice has been placed on top of posts the bottom panel and top sash for ceiling high partitions are then assembled and mop moulding connected to bottom base-rail of panel. The entire section is then raised and set in place between the posts.

The pilaster trim forms part of the post on one

side and on the opposite side is snapped on after the panel sections are in place. The pilaster caps and base caps are next applied, leaving only the ceiling filler to be cut to fit the space. Ceiling fillers of asbestos mill-board or steel are finished at building, if required, to match color of ceiling.

The placing of doors is equally simple, as the frames are interchangeable with standard 40-in. panels. Hinge leaves and strikes are applied at the factory. Therefore, where a door is to be placed the frame is installed as described above for a panel and later the door is hung.

Glazing is simply a matter of removing the loose glass stop, setting the glass in putty or rubber channels and screwing on the stop moulding.

Cleaning and polishing—the final operation—is practically negligible with Wright Metal Partitions, due to the high grade finish applied at factory.

### Provide Economical and Flexible Means for Installing Electrical Wiring

Another economy presented by Wright Metal Partitions is the ease with which electric wires for lighting and telephone service may be installed after the partitions are erected. Ample space for all necessary wiring is provided in all posts, cornices, chair rails and base. Removal of the snap-on pilaster covers affords instant and convenient access to the cables. Outlets for any purpose can be provided wherever desired. This feature eliminates the necessity of running conduits in the floor and provides great flexibility.

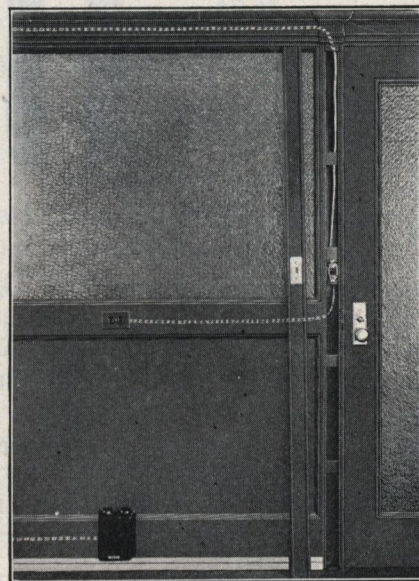

# GENERAL CONSTRUCTION FEATURES

## Wright Metal Partitions

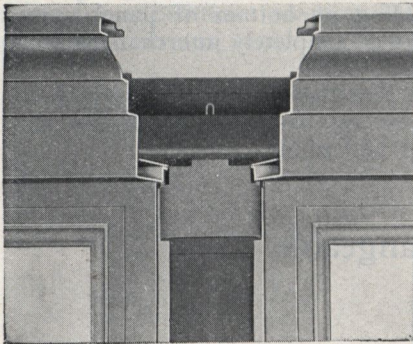

Detail D

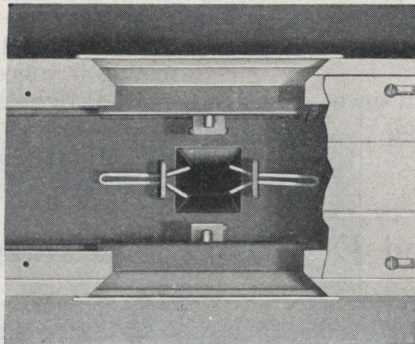

Detail E



Detail F

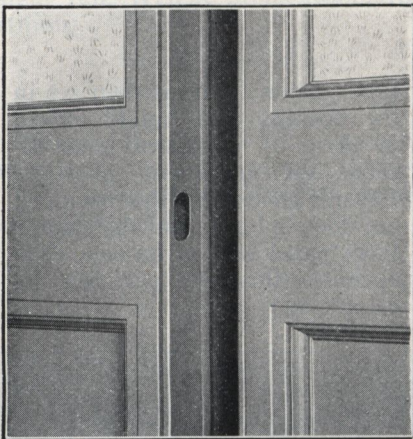

Detail C

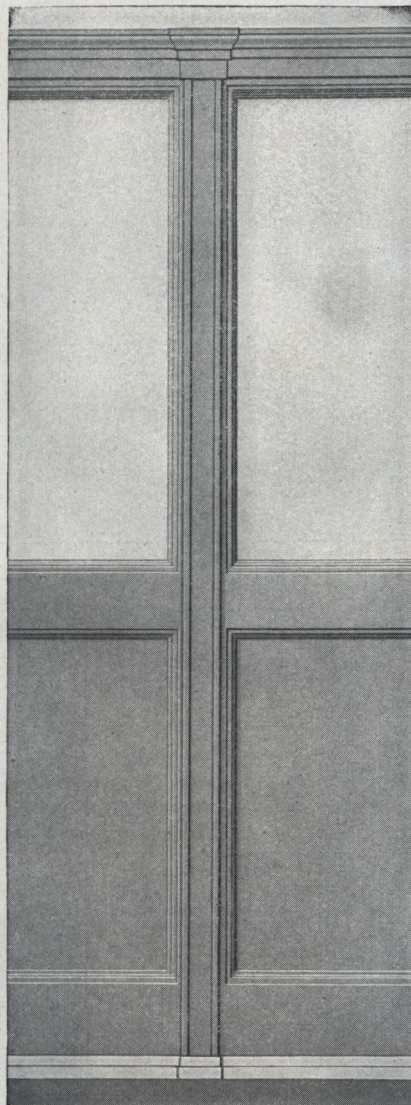

Detail A

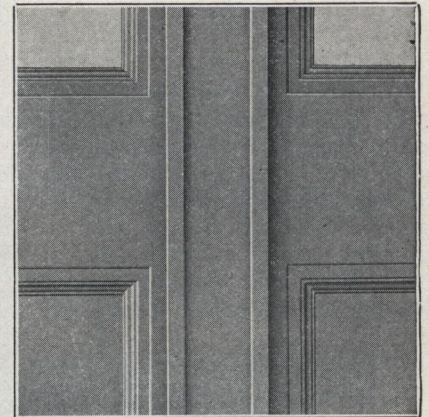

Detail G

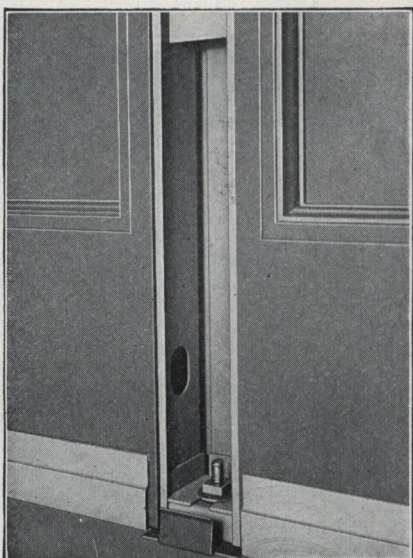

Detail B

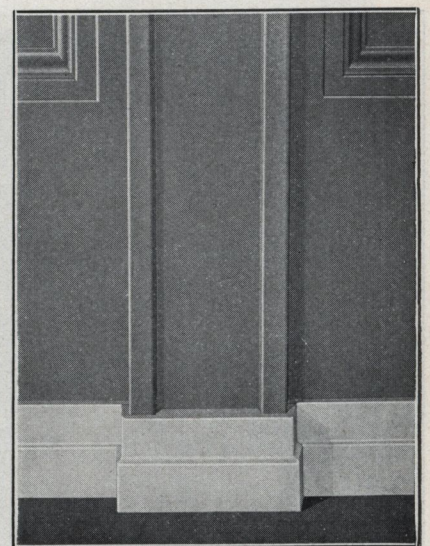

Detail H

*For Description of Illustrations, see preceding page*

## INTERCHANGEABILITY OF WRIGHT METAL PARTITIONS

Wright Metal Standard Partitions and Railings are absolutely interchangeable—a revolutionary advance in the hollow metal industry. This is made possible through the Wright Metal unit system of panel, cornice, mop moulding and pilaster construction. They are all reversible. Door frames and doors are also interchangeable with panel units.

Wall fillers provide necessary adjustment in all manner of rearrangements in any location.

Pilasters are recessed on four sides for instant setting of panel units, forming any type of enclosure—tee, cross, corner and straight run in erection. All cornice sections are mitered on each end for interchangeable accuracy. Mop moulding on bottom of panel units, pilasters and wall fillers is completely interchangeable—fastening is concealed.

All Wright Metal Partitions and Railings are fool-proof in erection—they are handsome in design and finish—they are sturdy and rigid.

### All Panels and Door Units Are Interchangeable

Every 40 and 64-in. panel unit is constructed so that instant change from panel to our standard stock door frame and swing door or doors can be made. The removal of snap-on pilaster covers on each side of the panel unit permits instant change of the entire panel sec-

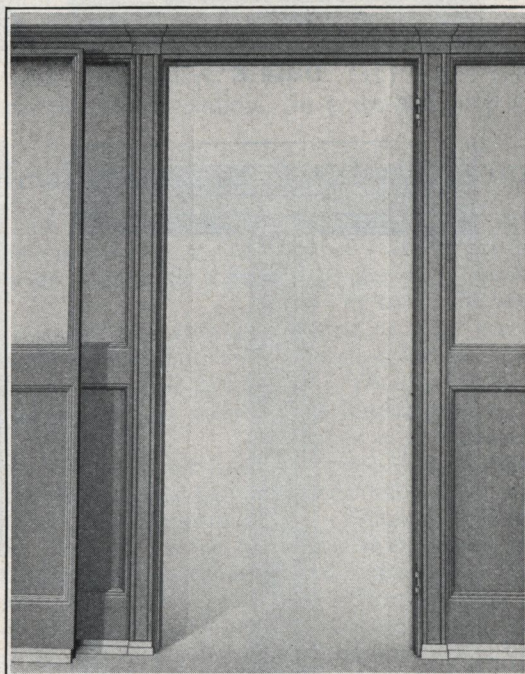

tion. Door frame is then set in the opening and rigidly locked in place by concealed bolts located on inside of pilasters. Pilaster covers are then snapped on, door is hung, and the change from panel section to new door opening through partition is completed.

Above:

#### Detail A

Illustrates 40-in. unit with our standard stock metal door frame set in same space previously occupied by panel section

Left:

#### Detail B

Illustrates same standard 40-in. panel unit with panel removed

Right:

#### Detail C

Illustrates same 40-in. unit and door frame with our standard 3x7-ft. stock metal door, properly hung in position. The change is complete

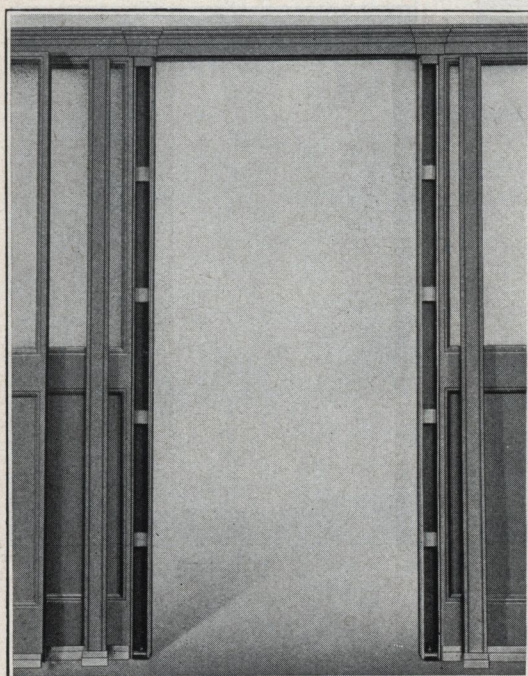

## FLEXIBILITY OF WRIGHT METAL PARTITIONS

### Panels Can Be Inserted at Pilasters to Form Straight, Angle or "T" Connections

All Wright Metal Standard Partitions are constructed for expeditious erection, taking down, or re-erection into various runs, as illustrated, by any one,

with no alterations. Every unit and every part of every unit is interchangeable. They are built to outlast the coming generation.

**Detail A**—Illustrates complete panel units connected to pilaster, in straight run, Wright Metal Standard Partition.

**Detail B**—Illustrates complete panel units connected to pilaster, forming "T" assembly of Wright Metal Standard Partition.

**Detail C**—Illustrates complete panel units connected to corner and end pilaster, also take-up wall filler, Wright Metal Standard Partition.

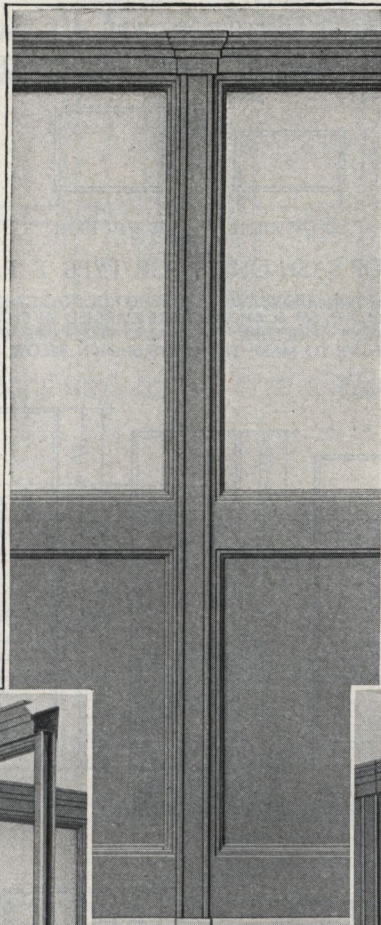

**Detail A**

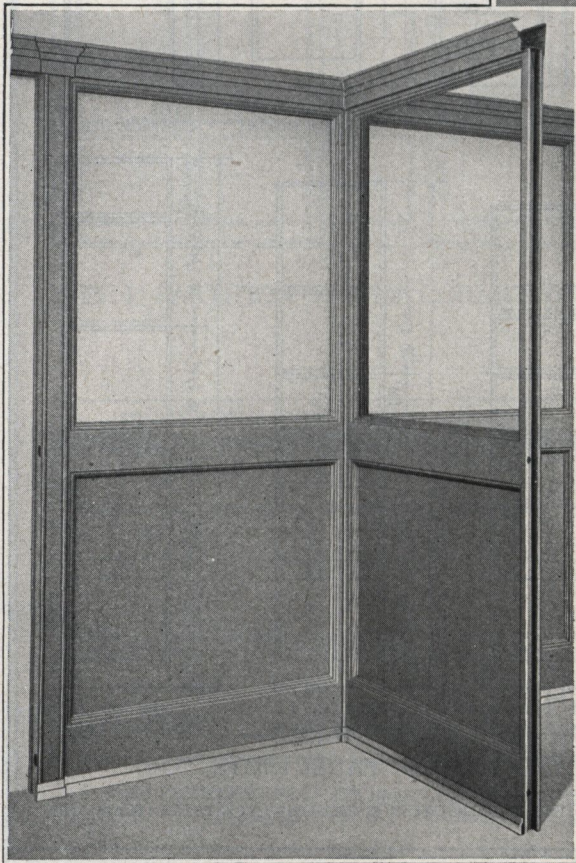

**Detail B**

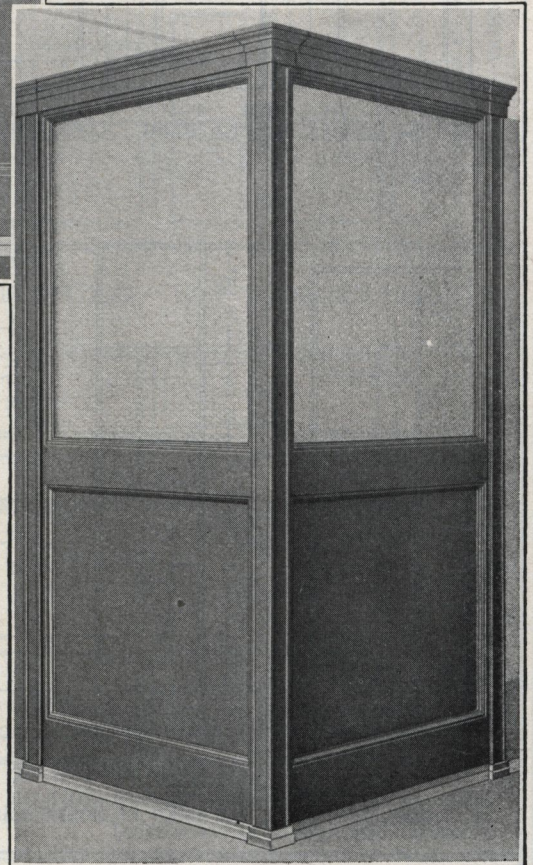

**Detail C**

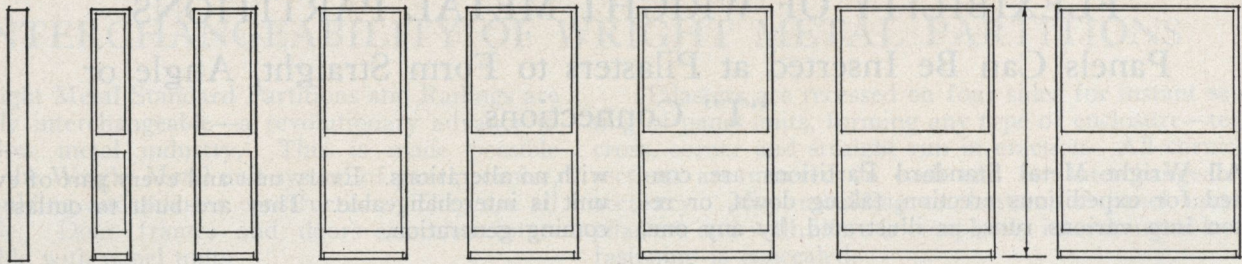

WALL FILLER 16" PANEL 3" TO 12"    24" PANEL    32" PANEL    40" PANEL    48" PANEL    56" PANEL    64" PANEL

TYPICAL PANEL UNITS FOR TYPE A E PARTITION AND BOTTOM PANELS FOR TYPE E PARTITION

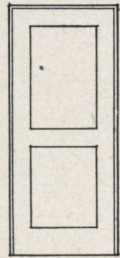

40" D A DOOR AND FRAME

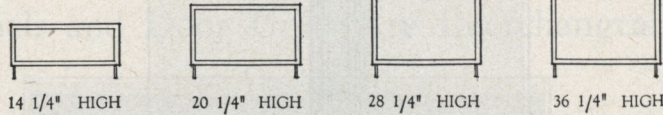

TYPICAL TOP SASH UNITS FOR TYPE E PARTITION

THE FOUR SASH SHOWN ABOVE ARE FURNISHED IN STANDARD PANEL WIDTHS OF 16", 24", 32", 40", 48", 56" & 64", AND ARE CARRIED IN STOCK. THESE SASH TELESCOPE TOGETHER. THEY ALSO TELESCOPE WITH THE BOTTOM PANELS SHOWN ABOVE TO MAKE THE UNITS SHOWN BELOW.

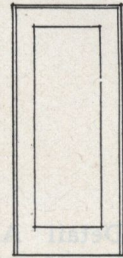

40" D B DOOR AND FRAME

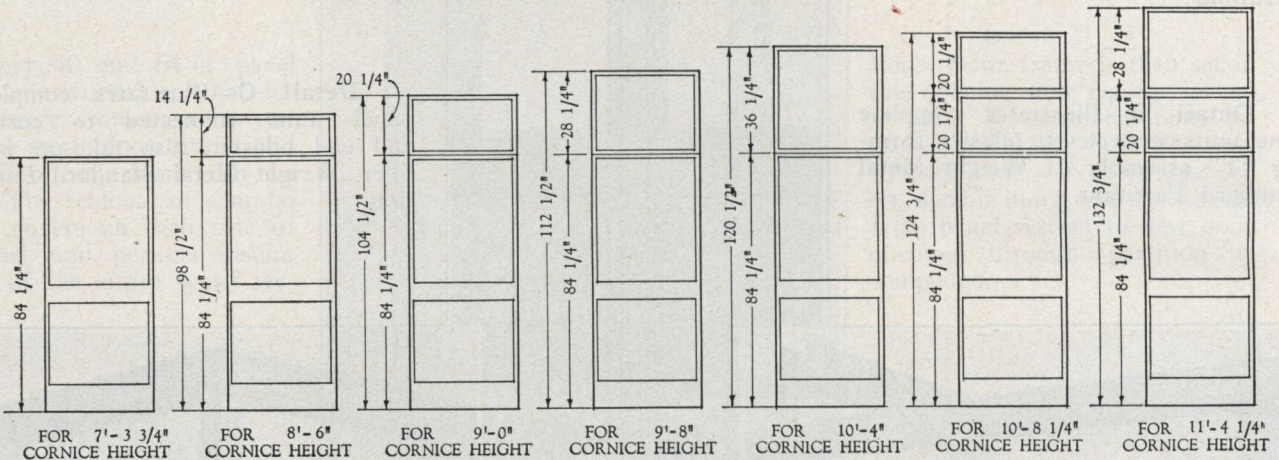

TYPICAL COMBINATIONS OF TOP SASH UNITS AND BOTTOM PANEL UNITS

THIS DETAIL SHOWS THE VARIOUS SIZE SASH ABOVE THE PANEL, AND THE ARRANGEMENT OF DIFFERENT SASH FOR VARIOUS CORNICE HEIGHTS. THE CEILING HEIGHT IS USUALLY ABOUT 12" HIGHER THAN THE CORNICE HEIGHT, AND THE SPACE BETWEEN IS CLOSED WITH A FILLER. (BEAM AND GIRDER CONDITIONS MUST BE CONSIDERED)

SASH AND PANEL STANDARDS

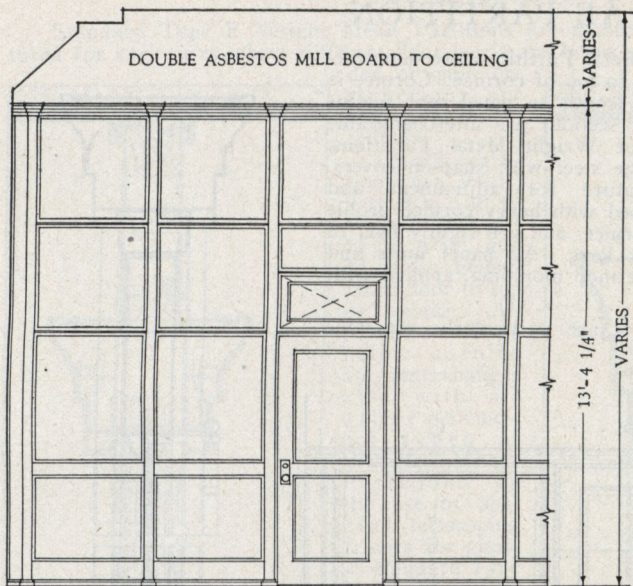

TYPE E PARTITION 13'-4 1/4" CORNICE HEIGHT

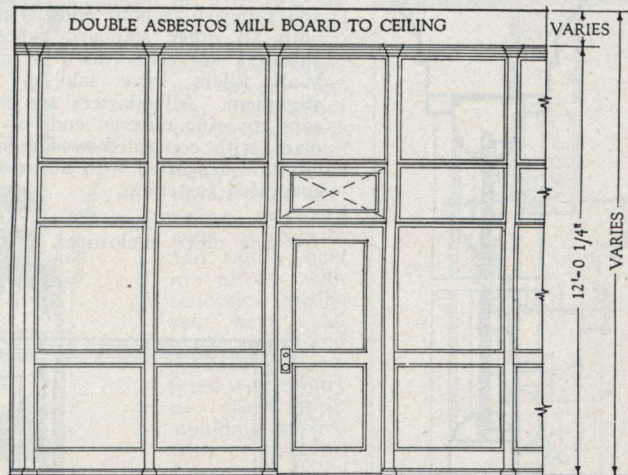

TYPE E PARTITION 12'-0 1/4" CORNICE HEIGHT

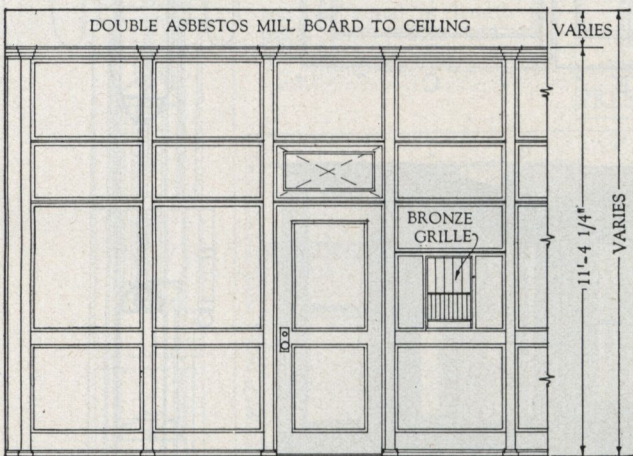

TYPE E PARTITION 11'-4 1/4" CORNICE HEIGHT

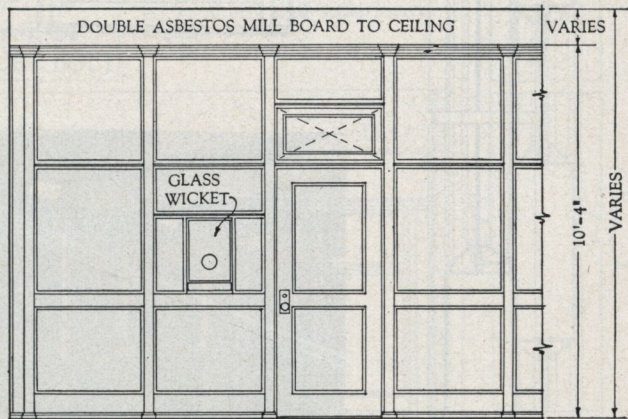

TYPE E PARTITION 10'-4" CORNICE HEIGHT

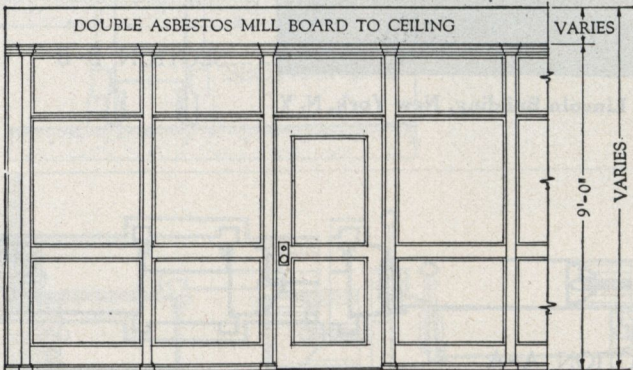

TYPE E PARTITION 9'-0" CORNICE HEIGHT

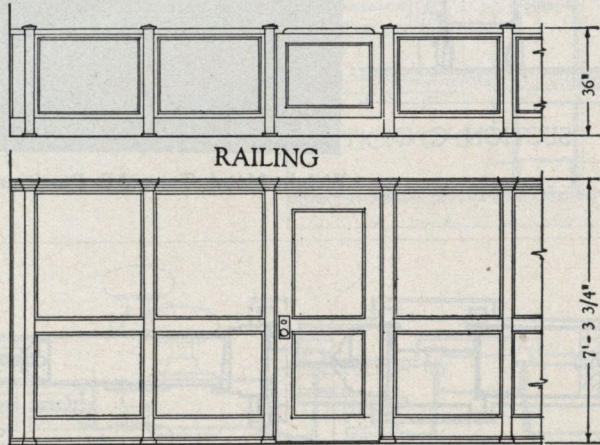

TYPE E PARTITION 7'-3 3/4" CORNICE HEIGHT

STANDARD E AND A E PARTITIONS AND RAILING

### STANDARD TYPE AE PARTITION

Standard Type AE Wright Metal Partitions are manufactured in 7 ft. 3 $\frac{3}{4}$  in. height, floor to top of cornice. Cornice is constructed in sections equal in length to panel unit widths and mitered at both ends. Panel sections are interchangeable with all other standard types of Wright Metal Partitions. Pilasters are cold drawn 18 gauge steel with snap-on covers. Wall fillers have take-up feature for adjustment and alignment. All pilasters are capped with heavy cornice profile caps covering mitered ends of cornice, and are rigidly held in place with concealed wedge split keys. All panel units and pilasters are fitted with adjustable mop moulding, applied with concealed fastening.

Standard Type AE partitions are particularly adaptable for fine office enclosures.

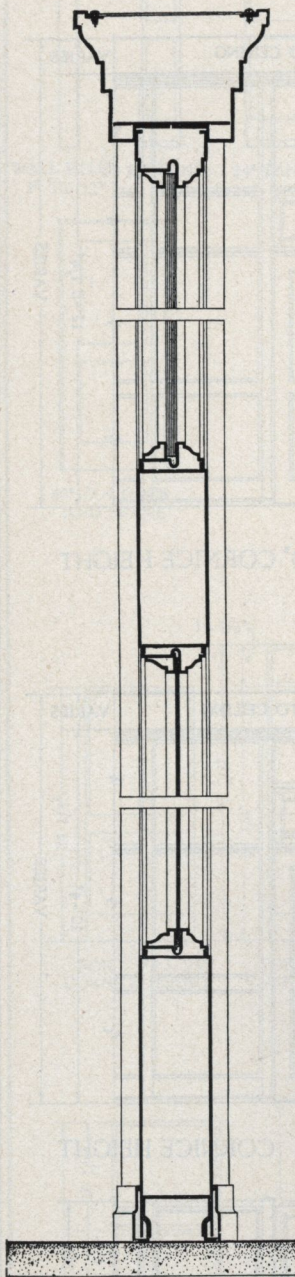

SECTION C-C

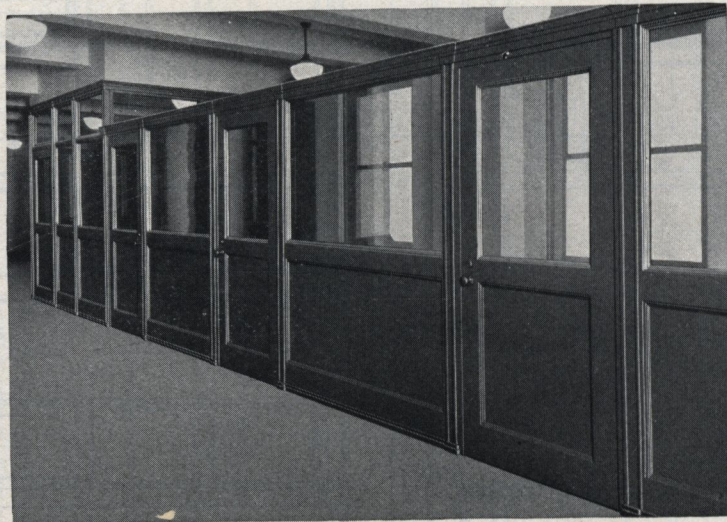
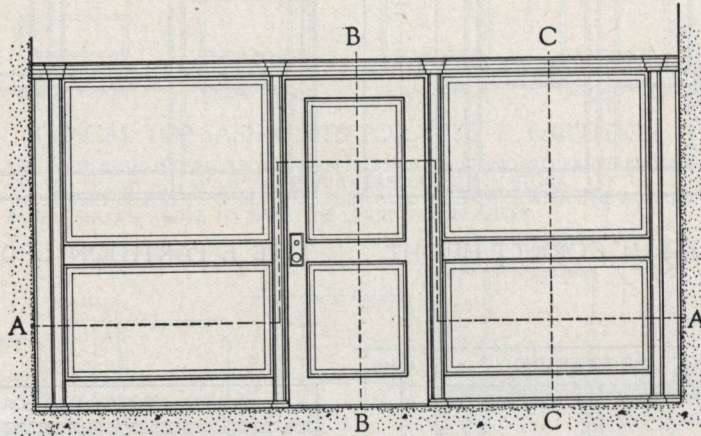

Wright Metal, Type AE, Partitions, Lincoln Building, New York, N. Y.

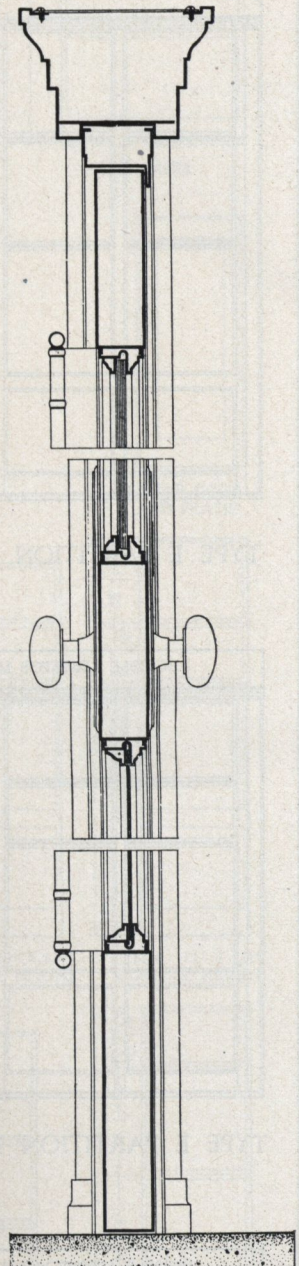

SECTION B-B

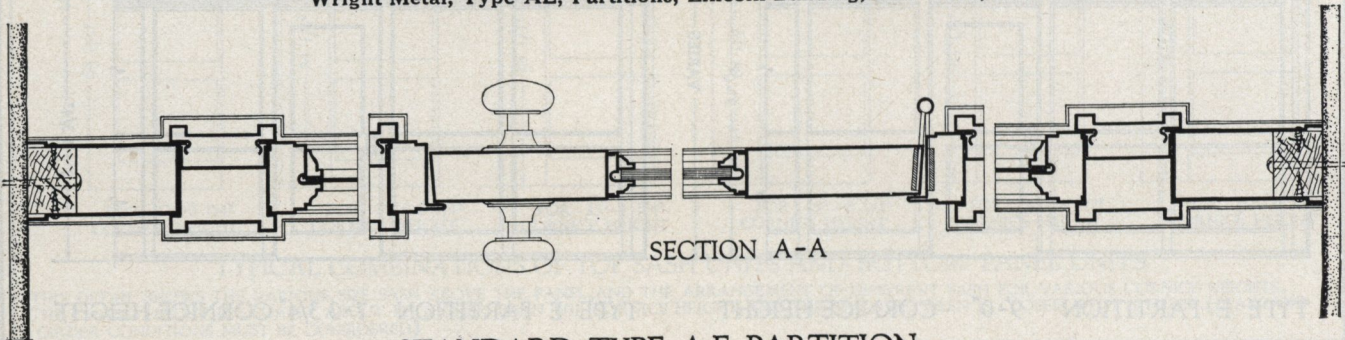

SECTION A-A

### STANDARD TYPE A E PARTITION

### STANDARD TYPE E PARTITIONS

Standard Type E Wright Metal Partitions are manufactured for enclosures where different floor levels and beam, girder or pipe obstructions are encountered at ceiling.

Stock partitions are 9 ft.; 9 ft. 8 in.; 10 ft. 4 in.; 10 ft. 8 in.; 11 ft. 4 in., and 12 ft. in height, from floor to top of cornice. All panel sections below cornice are interchangeable with all other standard types of Wright Metal Partitions. By the use of special telescoping frames for glass, all standard Type E partitions can be furnished from stock, for any height above regular standard panel height to level of lowest portion of ceiling beam or girder. Cornice is constructed in sections equal in length to panel unit widths and mitered at both ends. Above

cornice to ceiling a filler of either single or double steel plates, plaster or composition boards is erected and firmly held in place

with neat wall and ceiling scribe mouldings. All pilasters are cold drawn 18 gauge steel with snap-on covers and run from floor to cornice; they are capped with heavy cornice profile caps covering mitered ends of cornice and rigidly held in place with concealed wedge split keys. All panel units and pilasters are fitted with bronze or steel mop moulding, applied with concealed fastening.

Standard Type E partitions are beautiful, dignified and rigid in construction and, like all other types of Wright Metal Partitions, are 100% interchangeable and have 100% salvage value, the true test of economy and superiority.

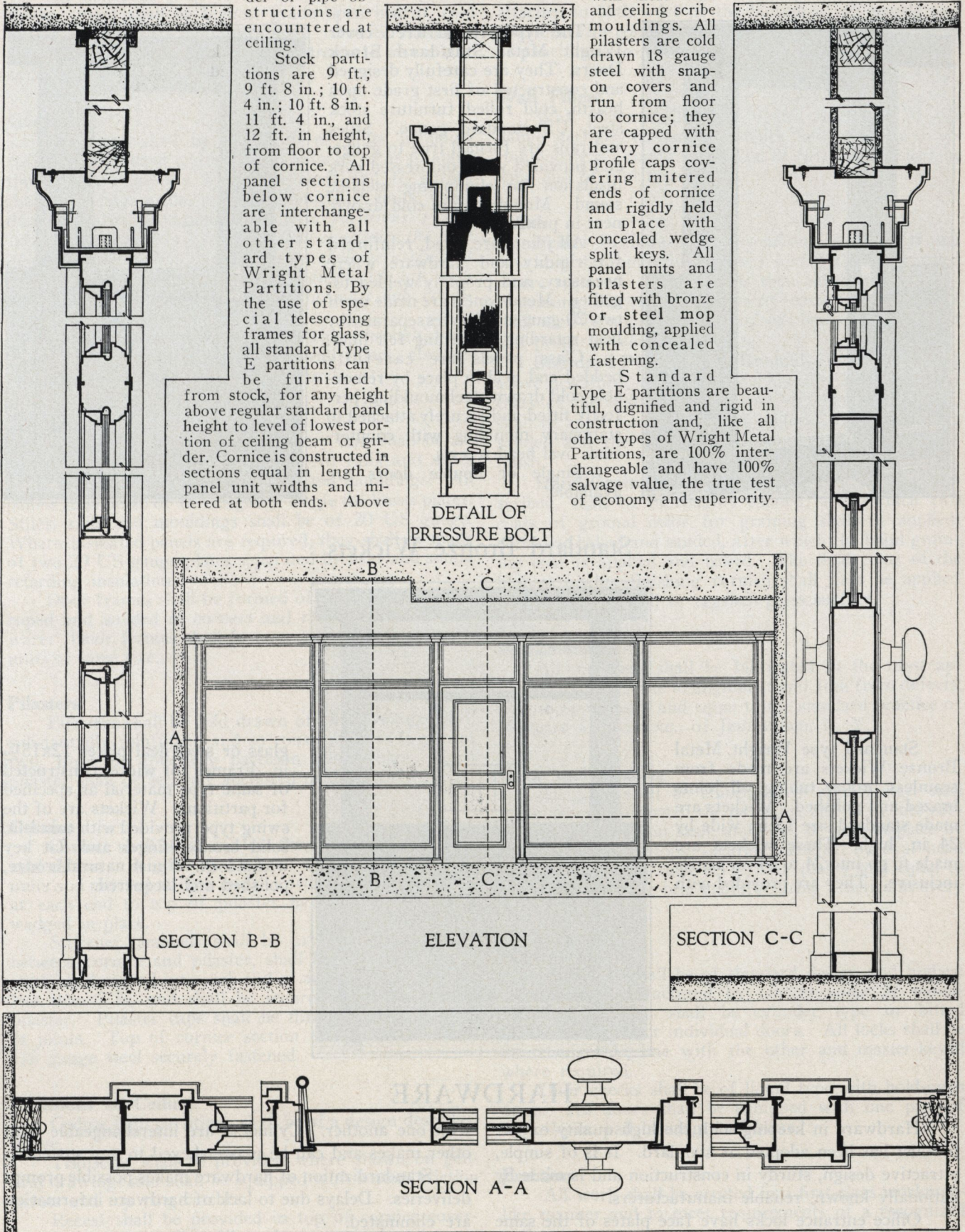

STANDARD TYPE E PARTITION

## WRIGHT METAL INTERCHANGEABLE UNITS

### Hollow Metal Doors

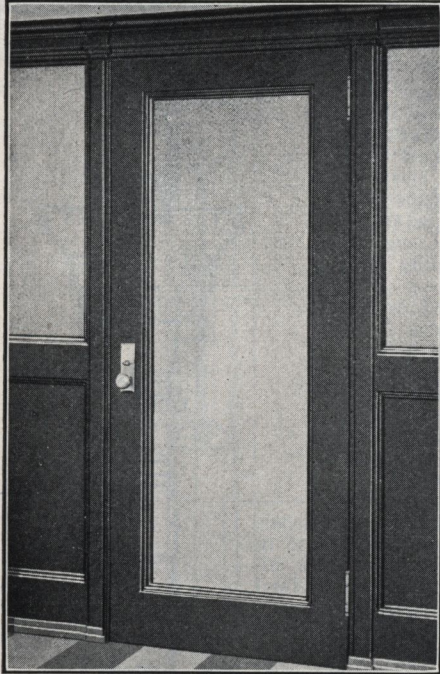

The types illustrated cover Wright Metal Standard Stock Doors. They are carefully designed and constructed of first grade open hearth, cold rolled furniture stock steel, US standard gauge. Stiles and rails are formed true to gauge, and provided with compressed cork insulation for eliminating metallic sound. Mouldings are cold drawn, neat in profile.

All joints are fitted, reinforced for rigidity and hardware where necessary, and properly welded together. Metal panels are made up of two 20-gauge steel plates separated by heat retarding deadening felt filler.

Glass panels are carefully bedded and held in place by removable cold drawn steel moulding, perfectly fitted and securely attached to stationary moulding with counter-sunk oval head screws.

Single or double doors are available.

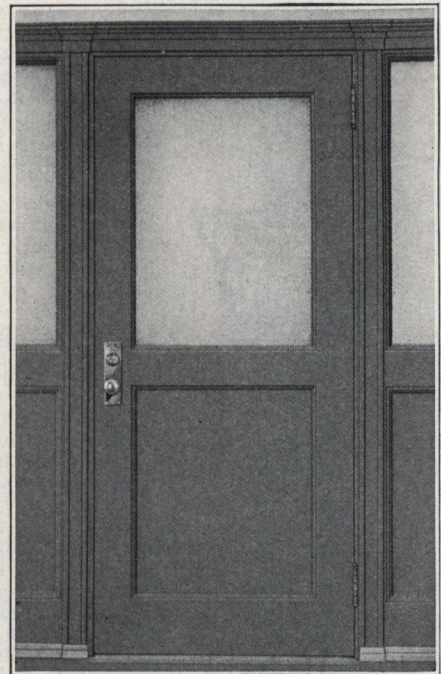

### Standard Bronze Wickets

Standard type Wright Metal Bronze Wickets are made from seamless bronze tubing, all joints brazed and polished. Wickets are made standard size 15 in. wide by 24 in. high. These wickets are made to go into 24 to 64-in. panels inclusive. They are provided with

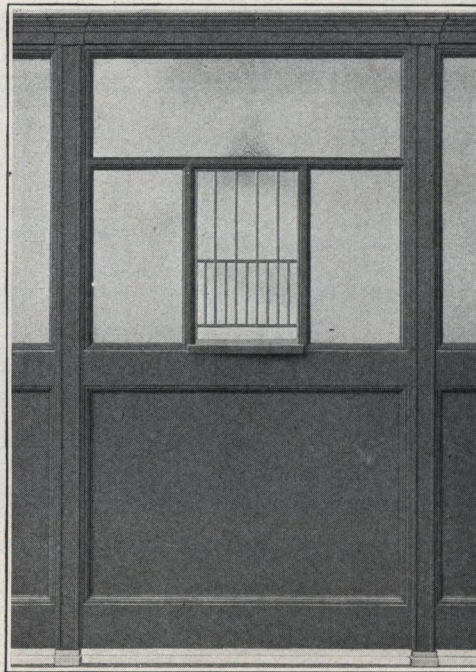

glass or steel deal plates 12x15½ in. Frames for wicket constructed of same type material as specified for partitions. Wickets are of the swing type, provided with two 3-in. solid bronze hinges and flat key wicket lock. Finish natural bronze, polished and lacquered.

## HARDWARE

Hardware in keeping with the high quality of our product has been adopted as standard. It is of simple, attractive design, sturdy in construction and is made by nationally known, reliable manufacturers.

Office entrance locks have face plates of the same size as communicating locks, and can be interchanged

with one another. Cylinders are interchangeable with other makes and can be master-keyed to any system.

Standardization of hardware makes possible prompt deliveries. Delays due to lack of hardware information are eliminated.

Other types of hardware can be used if desired.

## SPECIFICATIONS

### Materials

All materials shall be the best of their respective kinds. Steel shall be highest grade open hearth, cold rolled commercial furniture stock of US Standard gauge. All mouldings shall be cold drawn to insure true and uniform profiles.

### General

Partitions shall be made up of units including cornice of standard widths, so manufactured as to allow the utmost flexibility of arrangement and to permit changes being made without disturbing units other than those to be rearranged. *Low partitions (Type "AE" approximately 7 ft. high) shall constitute the base of all types. Ceiling high partition shall be assembled on the low partition with the addition of top sash and pilasters of varying heights to meet job conditions.*

All partitions must permit wiring through base, chair rails, cornice, pilasters and wall fillers, also accommodate standard electrical outlets.

### Description

Panels or sash in each and every case shall be assembled as one unit by welding. All rails and stiles being integrally welded with panels and mouldings. All panels shall be 16 or 18 US gauge single thickness plates. Stiles, rails and mouldings shall be of 20 US gauge. Where insulated panels are required, they shall be made of two 20 US gauge plates separated by heat and sound retarding insulation.

Door frames shall be formed of 18 US gauge steel, coped and welded at corners and reinforced for hardware. Door frames shall be interchangeable with panel units of same size.

### Pilasters

Pilasters shall be cold drawn of 18 US gauge steel, substantially reinforced and so constructed as to permit two, three or four-way partition connections. Each pilaster shall be securely anchored to the floor.

### Cornice

Cornice shall be of not less than 18 US gauge steel, cold drawn in lengths to conform with widths of panel units and mitered at both ends. Cornice shall be attached at each end to top of pilaster by split key, securely wedged in place.

Stiffener channels shall be provided at all joints between cornice and pilaster, shall be of 11 US gauge steel, shall extend into each end of adjoining cornice not less than 7 in. and shall be securely keyed to top of pilaster. Pilaster caps shall be fitted to cover cornice at joints. Top of cornice section to have cover of 16 US gauge steel securely fastened.

### Partitions to Ceiling

Ceiling high partitions shall be of a design described above.

Transoms shall be provided where shown on general drawings and shall be equipped with bottom friction pivots and top ring catches.

Recess shall be provided in top of cornice cover-plates to receive ceiling filler where required.

### Mop Moulding

Continuous bronze or steel mop moulding shall be attached to both sides of the bottom of all panels and pilasters with concealed fastening to permit adjustment of panel units to floor unevenness.

### Wall Fillers

Wall fillers shall be of double thickness 20 US gauge steel and of sufficient width and flexibility to accommodate all conditions. The fit to the wall shall be snug and of neat appearance.

### Finish

**Prime Finish**—After assembling, all oil, dirt and rust shall be removed. Exposed surfaces shall be filled where required. Each coat is then baked and sanded. A priming coat of the best quality, rust-resisting enamel shall then be applied to all surfaces both inside and out and properly baked.

**Standard Plain Baked Enamel**—Priming coat, as above described, shall be thoroughly sanded. Additional coats of the best quality enamel, of color as selected, shall be applied to all exposed surfaces, each coat to be sanded and the final coat to be of a dull semi-gloss finish.

**Hand Grained Finish**—Priming coat, as above described, shall be thoroughly sanded, after which two coats of ground color for graining shall be applied, each coat baked and sanded, after which the hand graining coat is applied and baked. The final coats of the highest quality finishing varnish shall then be applied and baked to a dull or eggshell gloss surface.

### Workmanship

All materials shall be fabricated in the most approved manner, true to alignment and free from defects, neat in appearance and equal to the standard practice of WRIGHT METAL INC., of Jamestown, N. Y.

### Glass and Glazing

All glass shall be embedded in special steel sash putty, colored to match the partition, and to fit into rabbets of the partition sash, and shall be held in place by removable metal stops, securely fastened by oval head screws. All glass shall be of first quality and equal to the standard of the best manufacturing practice in every respect.

### Hardware

Hardware shall be of standard design and highest quality as manufactured by (*insert name of manufacturer*). Locks shall be cylinder type or bitted key as specified for individual doors. All locks shall be interchangeable, one with the other and master-keyed where required.

Door checks shall be of liquid type with hold-open arms. All doors shall be equipped with one pair of 4½x4½-in. ball bearing steel butts.

### Erection

All work shall be erected in a first-class workman-like manner and to meet requirements of a recognized authority.

## WRIGHT METAL RAILINGS

Wright Metal Standard Open Base Railings are manufactured and carried in stock in two types, 3 ft. and counter height from floor. Pilasters are cold drawn 18-gauge steel with snap-on covers. Pilasters are rigidly attached to ornamental cast iron base. Tops of pilasters are covered with either cast bronze or cold drawn bronze caps, securely attached by concealed fastening. Panel sections are constructed and made up of cold drawn mouldings for stiles and rails and 18-gauge sheet steel panel plate. Panel sections are correctly fitted and firmly held in place, between pilasters, by concealed fastening.

Rail is heavy, pleasing in design and rigidly attached to pilasters without screws or bolts.

Wright Metal Standard Railings are made so they can be attached to any Wright Metal partition.

Gates are constructed perfectly square, with stiles, rails and panel moulding in strict keeping with all lines in panel sections. Gates are hung with latest approved double action sagless spring hinges.

All parts of Wright Metal Standard Railings are fully interchangeable. They combine great strength with minimum weight. They have no weak parts—they are absolutely rigid.

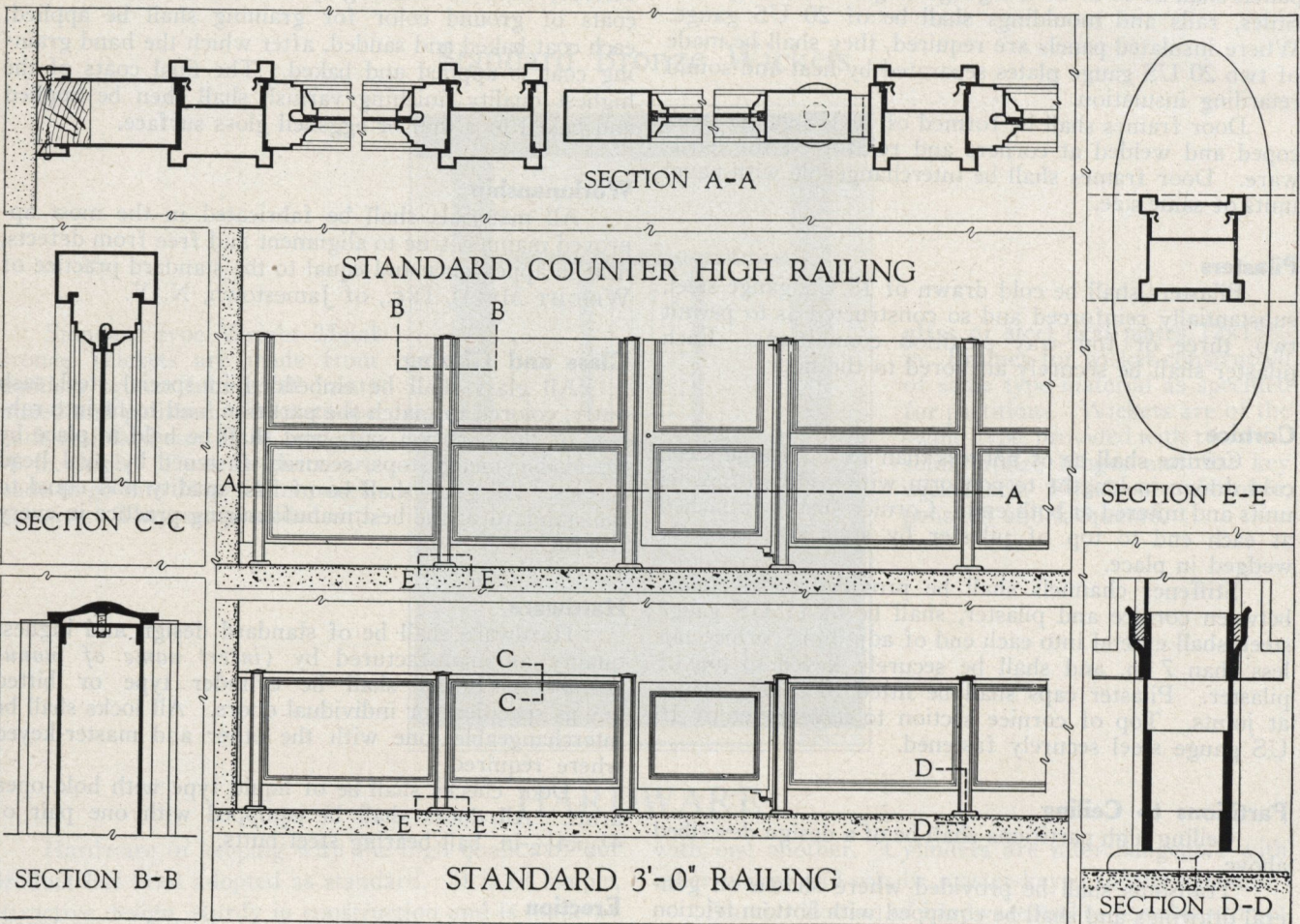
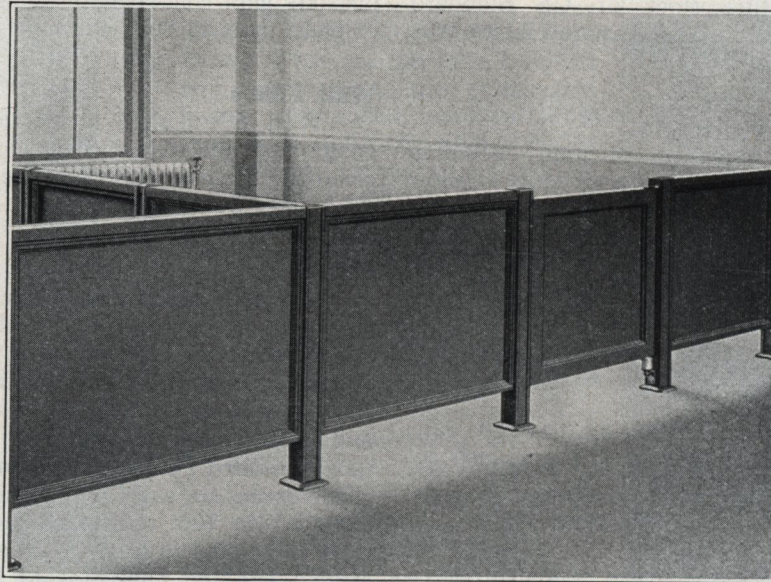

## SOME TYPICAL WRIGHT METAL INSTALLATIONS

FEDERAL RESERVE BANK . . . . .	Baltimore, Md.	NATIONAL BISCUIT COMPANY . . . . .	New York City
ATLANTIC NATIONAL BANK . . . . .	Boston, Mass.	DOBBS & COMPANY . . . . .	New York City
GLENS FALLS INSURANCE COMPANY . . . . .	Glens Falls, N. Y.	SPANG-CHALFANT & COMPANY, INC. . . . .	Pittsburgh, Pa.
FIRST NATIONAL BANK . . . . .	Sharon, Pa.	PARAMOUNT PUBLIX CORPORATION . . . . .	Chicago, Ill.
YONKERS NATIONAL BANK & TRUST Co. . . . .	Yonkers, N. Y.	UNITED ARTISTS CORPORATION . . . . .	Toronto, Canada
BANK OF JAMESTOWN . . . . .	Jamestown, N. Y.	GENERAL FIREPROOFING COMPANY . . . . .	Brooklyn, N. Y.
ROBERTS BUILDING . . . . .	Jamestown, N. Y.		
GENESEE COUNTY COURT HOUSE . . . . .	Flint, Mich.		
ERIE COUNTY COURT HOUSE . . . . .	Erie, Pa.		
N. Y. STATE COLLEGE OF AGRICULTURE . . . . .	Ithaca, N. Y.		
NORTH OFFICE BUILDING . . . . .	Harrisburg, Pa.		
J. H. CARPENTER, JR., INC. . . . .	New York City		
MADISON AVE. & 52ND ST. BUILDING . . . . .	New York City		
STANDARD OIL CO. OF NEW YORK . . . . .	Albany, N. Y.		
OHIO OIL COMPANY . . . . .	Findlay, Ohio		
STATLER BUILDING . . . . .	Boston, Mass.		
O'BRIAN, POTTER & STAFFORD . . . . .	Buffalo, N. Y.		
LINCOLN BUILDING . . . . .	New York City		
COLUMBIA BROADCASTING BUILDING . . . . .	New York City		
REALTY MANAGERS, INC. . . . .	New York City		
PLAZA BUILDING . . . . .	New York City		
JAMESTOWN TELEPHONE BUILDING . . . . .	Jamestown, N. Y.		
MEADVILLE TELEPHONE COMPANY . . . . .	Meadville, Pa.		
BELL TELEPHONE COMPANY OF PENNA. . . . .	Wilkinsburg, Pa.		
HOME TELEPHONE COMPANY . . . . .	Johnsonburg, Pa.		
NEW YORK TELEPHONE COMPANY . . . . .	Buffalo, N. Y.		
N. E. TELEPHONE & TELEGRAPH Co. . . . .	Worcester, Mass.		
N. E. TELEPHONE & TELEGRAPH Co. . . . .	Lawrence, Mass.		
MICHIGAN BELL TELEPHONE COMPANY . . . . .	Port Huron, Mich.		
NEW YORK TELEPHONE COMPANY . . . . .	Albany, N. Y.		
NEW YORK TELEPHONE COMPANY . . . . .	Ellenville, N. Y.		
NEW YORK TELEPHONE COMPANY . . . . .	Liberty, N. Y.		
NEW YORK TELEPHONE COMPANY . . . . .	Monticello, N. Y.		
PEOPLES TELEPHONE CORPORATION . . . . .	Butler, Pa.		
ROCHESTER TELEPHONE CORPORATION . . . . .	Rochester, N. Y.		
OLEAN CENTRAL OFFICE BUILDING . . . . .	Olean, N. Y.		
W. T. GRANT READY-TO-WEAR . . . . .	New York City		
GARFINKLE, ROSENBLATT & COMPANY . . . . .	New York City		
ECLIPSE MACHINE COMPANY . . . . .	Elmira, N. Y.		
HALE DESK COMPANY . . . . .	New York City		
FIRESTONE TIRE & RUBBER COMPANY . . . . .	Akron, Ohio		
JEWEL TEA COMPANY . . . . .	Barrington, Ill.		
ASSOCIATED GAS & ELECTRIC COMPANY . . . . .	Meadville, Pa.		
WORCESTER PRESSED STEEL COMPANY . . . . .	Worcester, Mass.		
ALCOA ORE COMPANY . . . . .	E. St. Louis, Ill.		
BETHLEHEM STEEL COMPANY . . . . .	Buffalo, N. Y.		
NATIONAL BISCUIT COMPANY . . . . .	Pittsburgh, Pa.		
DUPONT RAYON COMPANY . . . . .	Buffalo, N. Y.		
SYLVANIA PRODUCTS COMPANY . . . . .	Emporium, Pa.		
HOOKLESS FASTENER COMPANY . . . . .	Meadville, Pa.		
LARKIN STORE . . . . .	Buffalo, N. Y.		
N. Y. SCHOOL OF DESIGN . . . . .	New York City		
LIVERMORE & KNIGHT . . . . .	Providence, R. I.		
STERLING ENGRAVING COMPANY . . . . .	New York City		
NEW YORK AUTOMOBILE CLUB . . . . .	New York City		
N. Y. COUNTY COURT HOUSE . . . . .	New York City		
M. ROTHKRUG . . . . .	New York City		
KAPLAN & RODNICK . . . . .	New York City		
PAN-AMERICAN AIRWAYS . . . . .	New York City		
AMERICAN MAIZE PRODUCTS COMPANY . . . . .	New York City		

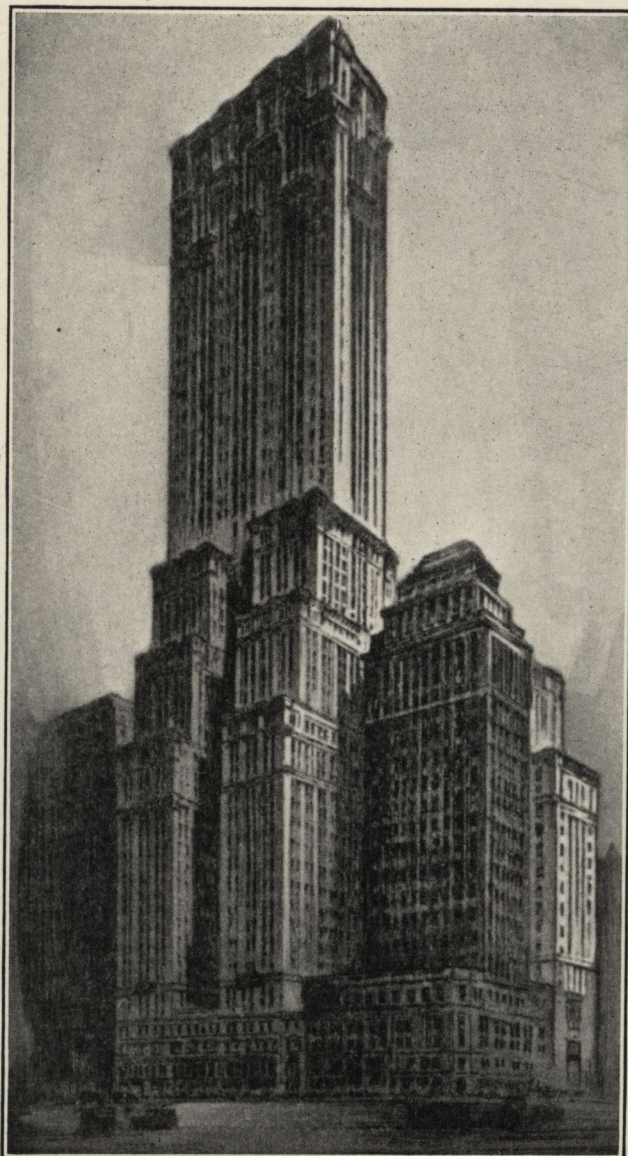

Lincoln Building, 42nd Street and Madison Avenue,  
New York, N. Y.

J. E. R. CARPENTER, Architect  
LINCOLN 42ND STREET CORPORATION, Owners  
WARREN & WETMORE, Supervising Architects  
DWIGHT P. ROBINSON & Co., Inc., General Contractors

*All metal partitions—many miles in total length  
—in the new Lincoln Building have been installed  
by Wright Metal Inc.*

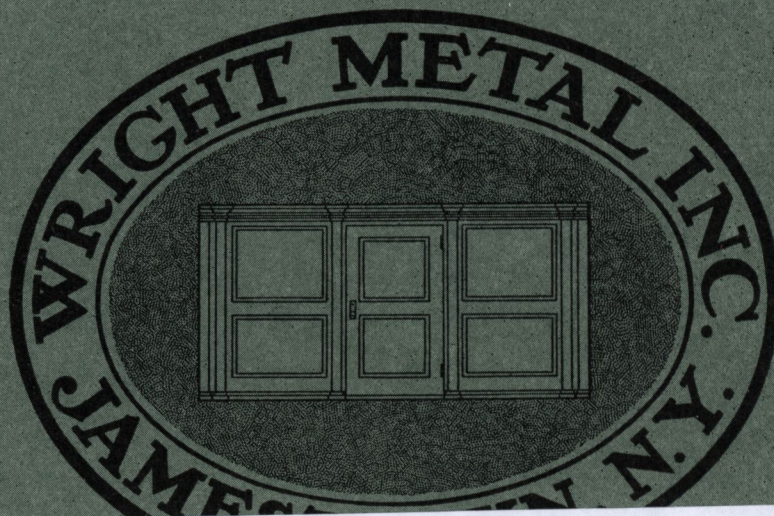

Digitized by:



ASSOCIATION  
FOR  
PRESERVATION  
TECHNOLOGY,  
INTERNATIONAL  
[www.apti.org](http://www.apti.org)

BUILDING  
TECHNOLOGY  
HERITAGE  
LIBRARY

<https://archive.org/details/buildingtechnologyheritagelibrary>

From the collection of:  
Robert Vail Cole Jr, AIA  
1962 - 2011

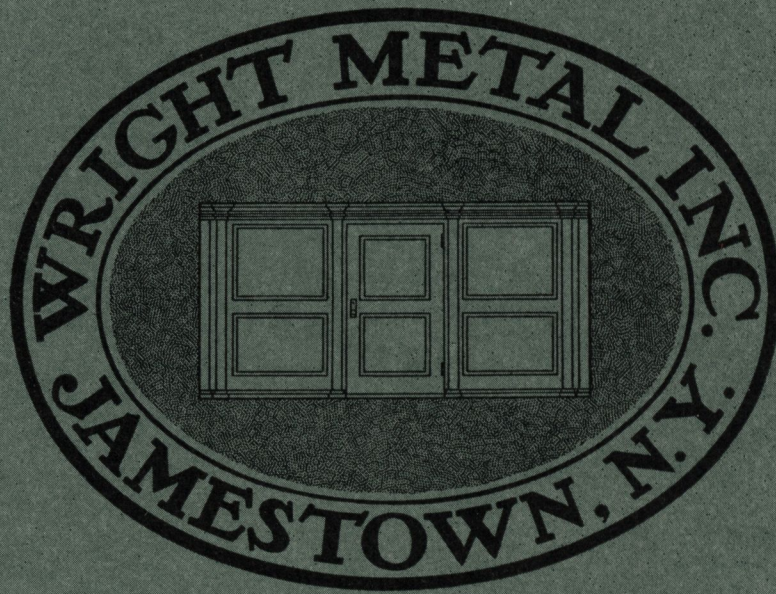

WRIGHT METAL INC., JAMESTOWN, N. Y.  
NEW YORK OFFICE — 205 EAST 42nd STREET  
TELEPHONE — MURRAY HILL 5889